

Trimtrac Pro Auxiliary Alarm

Application Note

Overview

This Application Note describes how to install, setup, and use the Auxiliary Alarm event for the Trimtrac Pro GPS beacon. This document should be used in conjunction with other support tools, such as the installation guide, and the online help system.

The Auxiliary Alarm event can enable two different inputs – the Power Cut Alert, and the Run Time Meters. You can only set up one event for the Auxiliary Alarm, but you can set up either the Power Cut Alert or the Run Time Meters on their own, or together at the same time, but this must be done within the same Auxiliary Alarm event. If you are setting up both inputs at the same time, then you should use the wiring diagram indicated under the Run Time Meter section.

Power Cut Alert

The Power Cut Alert for the Trimtrac Pro provides you with the ability to receive an automated email, SMS, or monitoring station alert (if applicable) if the DC power to your beacon is cut or otherwise removed. In order to enable this alert, the beacon must be installed and wired correctly first, and then the correct scenario events must be created in your portal. Also note that if your beacon does have the power cut, you will need to reset the alert from your portal.

Installation

Please follow the wiring diagram below to correctly enable the Power Cut alert. This wiring diagram should be used in conjunction with the standard installation guide for the Trimtrac Pro.

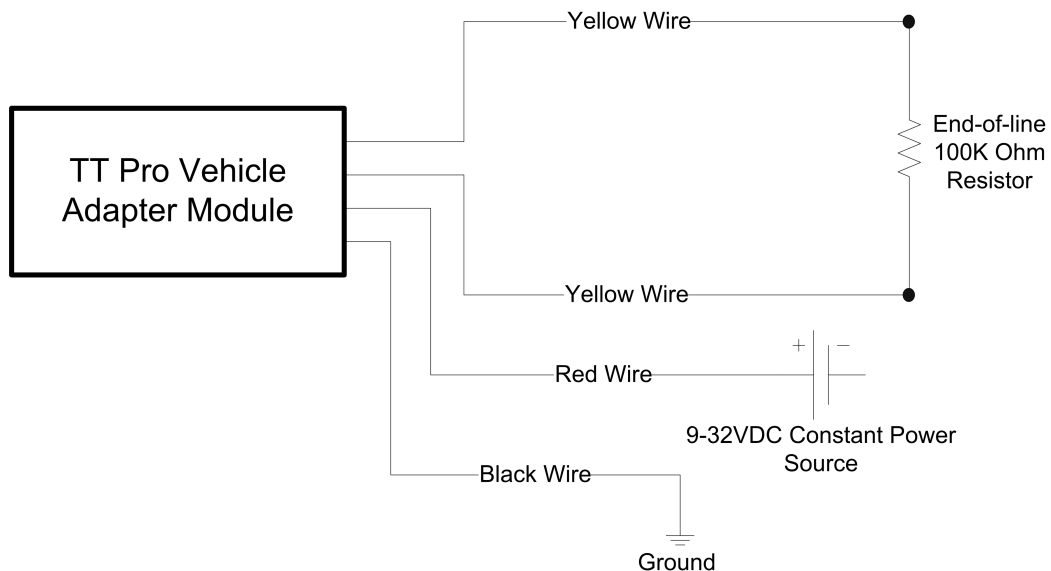

Scenario Manager Setup

The Power Cut alert is part of the Auxiliary Alarm event in the Scenario Manager. Setting up the Power Cut alert involves accepting the warning and then enabling the Power Cut alert by clicking the “enable” check box. You can also select whether or not you wish to receive alerts for the Power Cut events. If you select to receive alerts, then each time a Power Cut event is received by the system, the system will send an alert to your designated notification group once you have completed the entire scenario set up.

NOTE: It is critical that you have the proper wiring completed prior to setting up the scenario, otherwise your beacon may continue to report erroneous Power Cut events repeatedly.

Input #2 - Power Cut Alert
Enabling Power Cut will program the beacon to alert the system if the DC power to the VAM has been cut (the beacon will continue to operate for up to 4 hours on an internal battery).

Warning: The Power Cut Alert requires proper installation of a resistor according to the wiring diagram (see sidebar).
If you enable this feature without the resistor, the beacon will repeatedly generate erroneous power cut alerts.

I have read this warning and will complete the wiring prior to enabling this alert.

Installation Tips
You must follow the wiring diagram in the Auxiliary Alarm Application Note to install this input.

You must enable the Power Cut Alert for the system to properly configure the beacon:

Enable Power Cut Alert
 Send notifications for these messages

Each Power Cut alert can use up to 5 messages.

Resetting the Power Cut Alert

In the case where the power is cut to your Trimtrac Pro, the beacon will generate an alert to the system and notify you. From this point, your Trimtrac Pro will function for approximately 3 to 4 hours on the internal backup battery (depending on the frequency of transmission and your GPS settings), and you must restore power to have the beacon continue to function.

During the time that the power to the Trimtrac Pro has been cut, the beacon will only send the alarm one time. When power has been restored to the beacon, a command must be sent to the beacon to reset the parameter that will enable the beacon to send a Power Cut alert the next time the power is cut to the beacon.

Once the power has been restored, a button labeled “Reset” will appear in the Item or Beacon Output Control Panel. Clicking this button will send the reset command to the beacon. After the command has been sent, the button will no longer be available.

If you do not manually reset the power cut, the system will attempt to automatically reset the power cut. The system does this by examining the data that is received by the beacon, and if the data indicates that power has been restored, the reset will occur automatically. This automatic reset is done on a best efforts basis and it is recommended that you manually reset the alert any time the power is cut.

Run Time Meter

The Run Time Meter for the Trimtrac Pro provides the ability to have the running time for an engine or other switched contact (such as a Power Take Off) accumulated by the beacon and reported at an interval you specify. When the beacon reports the run time meter, this data can be used in the Commercial Portal Maintenance Module to trigger maintenance alerts for things such as oil changes. Additionally, the run time meter can be measured using the Engine Hours report in the system.

Installation

Please follow the wiring diagram below to correctly enable the Run Time Meter. This wiring diagram should be used in conjunction with the standard installation guide for the Trimtrac Pro.

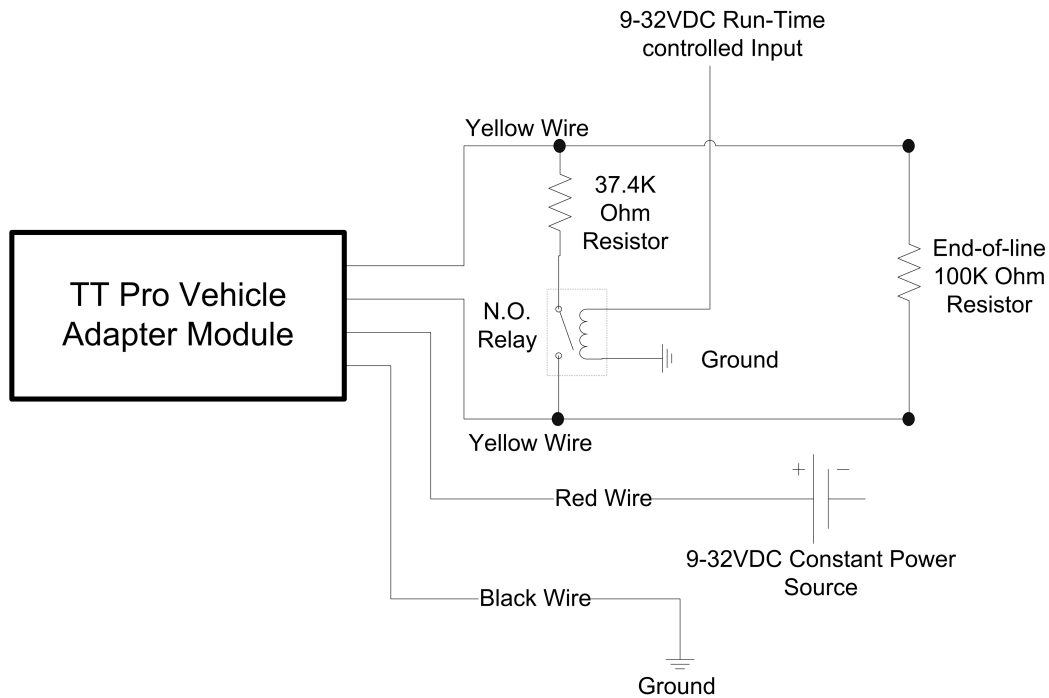

Scenario Manager Setup

The setup for the Run Time Meter is part of the Auxiliary Alarm event in the Scenario Manager. Setting up the Run Time Meter involves first turning on the feature by clicking the "enable" check box. Once the feature is enabled, you can choose to have the system poll your beacon for the Run Time hours in any combination of daily request, such as every day, only on a specific day of the week, or on multiple days of the week. You can also choose to have the Run Time hours polled on the last day of the month. The Run Time Hours polling occurs as near to midnight as possible. This schedule will automatically repeat as long as your Auxiliary Alarm event is enabled.

You can also poll the beacon for its Run Time hours at any time by using the "Request Update" button in the Beacon Control Panel. This can be found in the detail



view of the Item that the beacon is assigned to, or in the Beacon Details page under Administration.

NOTE: It is critical that you have an "Always On" Position/Status Scenario set up to use the Run Time Meters. If you set up the Run Time Meters and do not have the configuration set to "Always On", the Run Time Meters will not function properly.

Input #1 - Run Time Meter
The Run Time Meter will accumulate running hours whenever the switch contacts are closed. This is useful for determining how long an engine has been running for maintenance, for example.

Warning: You must have an "Always On" Position/Status Scenario set up to use the Run Time Meters

Installation Tips
You must follow the wiring diagram in the Auxiliary Alarm Application Note to install this input.

You must enable the Run Time Meter for the system to properly configure the beacon:
 Enable Run Time Meters

Report Run Time Meter every (at midnight)
 Mon Tues Weds Thurs Fri Sat Sun

Note: Setting the Run Time Meter to report more frequently will use more messages.
You can poll the beacon for its Run Time meters in the Item details page.

It is important to understand that each request to update the run time hours will use two messages, so please keep this in mind when setting up the scenario.

Using the Run Time Meters

The Run Time Meters are valuable for measuring total engine hours for maintenance, or the hours that a particular piece of equipment uses during a certain time frame for billing purposes. When using the Trimtrac Pro for these applications, it is important to take into consideration that the Trimtrac Pro will only report the run time hours on an infrequent basis, and that you will generally not always have absolutely current data. If you need an immediate update, please use the polling feature.